

data sheet

ARGCO



Fire Sprinkler Pressure Gauge 0-80-250# Air W/Retard



Item #6510162
0-80-250# Air W/Retard

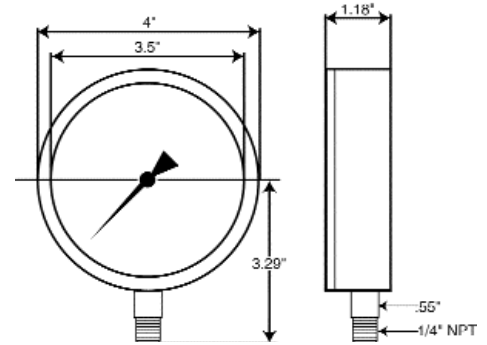

Application: Fluid medium which does not clog connection port or corrode copper alloy. Specifically designed for the fire sprinkler industry.

Size: 4" (100 mm)

Accuracy $\pm 3/2/3\%$ of span (ASME B40.1 Grade B)

Working Range

Steady: $3/4$ of full scale value
Fluctuating: $2/3$ of full scale value
Short time: full scale value

Operating Temperature

Ambient: -40°F to 140°F (-40°C to 60°C)
Media: max. 140°F ($+60^{\circ}\text{C}$)

Temperature Error

Additional error when temperature changes from reference temperature of 68°F (20°C) $+0.4\%$ for every 18°F (10°C) rising or falling. Percentage of span.

Standard Features

Connection Material: copper alloy
Lower mount (LM) - not available for $1\frac{1}{2}$ " size
 $1/4$ " NPT limited to wrench flat area

Bourdon Tube: Material: copper alloy C-type

Movement: Copper alloy, silicone dampened

Dia: White plastic with stop pin - black & red lettering

Pointer: Black aluminum

Case: Black polycarbonate

Approvals

UL listed (UL-393)
FM approved
Meets NFPA 25 Standards

Standard Scale

PSI

Window

Acrylic, ultrasonically welded to case

Standard Series • Type 110.10sp

The information contained herein is produced in good faith and is believed to be reliable but is for guidance only. ARGCO and its agents cannot assume liability or responsibility for results obtained in the use of its product by persons whose methods are outside or beyond our control. It is the user's responsibility to determine the suitability of any of the products, methods of use, or preparation prior to use, mentioned in our literature. It is the user's responsibility to observe and adapt such precautions as may be advisable for the protection of personnel and property in the handling and use of any of our products.

**FOR MORE INFORMATION CALL ARGCO AT 1-800-854-1015
OR LOG ONTO WWW.ARGCO.COM**

CERTIFICATE OF COMPLIANCE



WIKAL Instrument, LP
1000 Wiegand Boulevard
LAWRENCEVILLE, GA 30043
Tel : (+1) 770-513 8200
Fax : (+1) 770-338 5118
<http://www.wika.com>
info@wika.com

Wika Instrument, LP Certifies that the products specified herein have been manufactured in accordance with established technical standards, and comply with the requirements of ANSI/ASME B40.100

CUSTOMER	Allied Rubber & Gasket Co 5400 S 66 St FORT SMITH, AR 72903
CUSTOMER P.O. NO.	41945
ORDER NO.	2018647
ORDER DATE	04/14/2015
CUSTOMER P/N	6510161
WIKAL P/N	4276192
DESCRIPTION	111.10SP 4 300IPS 1/4 L WATER ARGCO
QUANTITY	4,800
AUTHORIZED SIGNATURE	<i>Bernadette H. Biggs</i>
DATE	04/15/2015

