

# GROOVED FLANGE ADAPTER NIPPLES

## Model 802



The Model 007A1 Flange Adapter allows for direct connection of a grooved system to ANSI class 12/150 flanged components

### Pipe Material

- Carbon steel, Schedule 10, Schedule 40.  
For use with alternative materials and wall thicknesses please contact ARGCO.

### Maximum Working Pressure

- Up to 300 psi/17 bar

### Function

- Joins carbon grooved pipe system to flange components

### CERTIFICATIONS/LISTINGS

Underwriters Laboratories, Underwriters Laboratories Canada, Factory Mutual.

### SPECIFICATIONS - MATERIAL

**Housing Sections:** Ductile Iron conforming to ASTM A 536, Grade 65-45-12.

### Housing Coating:

Standard: Hot Dipped Galvanized

Available: Orange Enamel

System No.		Location		Spec Section		Paragraph	
Submitted By		Date		Approved		Date	

# GROOVED FLANGE ADAPTER NIPPLES

## Model 802

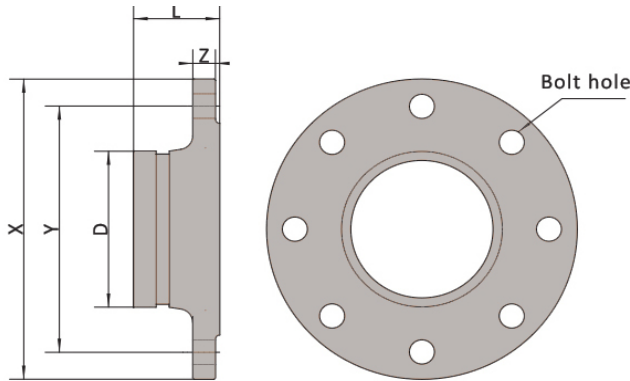

Item #	Nominal Size in/mm	Pipe O.D. in/mm	Max. Working Pressure PSI/Bar	Dimensions				Bolt Holes No.	Bolt Size in/mm
				X inches mm	Y inches mm	Z inches mm	L inches mm		
7012630A	2	2.375	300	6.10	4.74	0.63	2.56	4	5/8
	50	60.3	20	155	120.5	16	65	4	M16
7012630	2-1/2	2.875	300	7.09	5.51	0.63	2.56	4	5/8
	65	73.0	20	180	140	16	65	4	M16
7012631	3	3.50	300	7.48	6.02	0.71	2.65	4	5/8
	80	88.90	20	190	153	18	65	4	M16
7012632	4	4.50	300	9.06	7.52	0.87	2.76	8	5/8
	100	114.30	20	230	191	22	70	8	M16
7012633	5	5.563	300	10.04	8.50	0.87	2.76	8	3/4
	125	141.3	20	255	216	22	70	8	M20
7012634	6	6.625	300	11.02	9.49	0.87	2.76	8	3/4
	150	168.30	20	280	241	22	70	8	M20
7012635	8	8.625	300	13.58	11.77	0.98	3.15	8	3/4
	200	219.1	20	345	299	25	80	8	M20
7012636	10	10.75	300	15.94	14.25	1.02	3.35	12	1
	250	273	20	405	362	26	85	12	M24
7012637	12	12.75	300	19.09	17.01	1.10	3.54	12	1
	300	323.9	20	485	432	28	90	12	M24

### User Responsibility for Product Selection and Suitability

Each user bears final responsibility for making a determination as to the suitability of ARGCO products for a particular end-use application, in accordance with industry standards and project specifications, and the applicable building codes and related regulations as well as ARGCO performance, maintenance, safety, and warning instructions. Nothing in this or any other document, nor any verbal recommendation, advice, or opinion from any ARGCO employee, shall be deemed to alter, vary, supersede, or waive any provision of Allied Rubber and Gasket Company's standard conditions of sale, installation guide, or this disclaimer.

### Note

All products to be installed in accordance with current ARGCO installation/assembly instructions. ARGCO reserves the right to change product specifications, designs and standard equipment without notice and without incurring obligations.

### Installation

Reference should always be made to the ARGCO installation instructions of the product you are installing.

### Warranty

Refer to the Warranty section of the current Price List or contact ARGCO for details.

System No.		Location		Spec Section		Paragraph	
Submitted By		Date		Approved		Date	