

GROOVED REDUCING COUPLINGS

Model 105



The ARGCO Model 105 reducing coupling allows for direct reduction on a piping run and eliminates the need for a concentric reducer and couplings. The specially designed rubber gasket helps prevent small pipe from telescoping into larger pipe during vertical assembly.

Caution: Model 105 couplings should not be used with an end cap, as the end may be sucked into the pipe when draining the system.

Pipe Material

- Carbon steel, Schedule 10, Schedule 40.

For use with alternative materials and wall thicknesses please contact ARGCO.

Maximum Working Pressure

- Up to 300 psi/2517 kPa.

Function

- Joins carbon steel pipe.
- Provides a rigid pipe joint designed to restrict axial or angular movement.

CERTIFICATIONS/LISTINGS

Underwriters Laboratories, Underwriters Laboratories Canada, Factory Mutual.

SPECIFICATIONS - MATERIAL

Housing Sections: Ductile Iron conforming to ASTM A 536, Grade 65-45-12.

Housing Coating:

Standard: Hot Dipped Galvanized

Available: Orange Enamel

Gasket:

Standard: Grade E EPDM (Type A)

ARGCO's products are listed by Underwriters Laboratories UL Canada and Approved by Factory Mutual for we and dry (oil free air) sprinkler services within the rated working pressure.

Bolts and Nuts

Standard: Carbon Steel oval neck track bolts meeting ASTM A449 and ISO 898-1. Carbon steel hex nuts meet ASTM A563 Grade B.

Nuts and Bolts are zinc electroplated per ASTM B633 NZ/FE5, finish Type III.

Available: Stainless Steel. Meets ASTM F593, Group 2 (316 stainless steel), condition CW.

Hex nuts meets ASTM F594, Group 2 (316 stainless steel), condition CW, with galling-resistant coating.

System No.		Location		Spec Section		Paragraph	
Submitted By		Date		Approved		Date	

GROOVED REDUCING COUPLINGS

Model 105

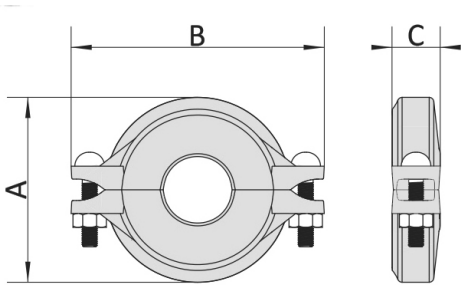

ARGCO Grooved Couplings are suitable for fire protection systems, water supply systems, and other process systems of higher working pressure.

Item #	Nominal Size in/mm	Actual O.D. in/mm	Max. Working Pressure psi/Bar	Max. End Load Lbs/KN	Axial Displacement in/mm	Deflection		Dimensions			Bolt Size inches mm
						Degree Per Coupling (°)	Pipe in/ft mm/m	A inches mm	B inches mm	C inches mm	
7010109	1-1/2 x 1-1/4	1.9 x 1.669	300	852	0.0625	1° - 54'	33	2.76	4.45	1.77	3/8 x 2
	40 x 32	48.3 x 42.4	20	3.79	1.6	1° - 54'	0.4	70	113	45	M10 x 50
7010110	2 x 1-1/4	2.375 x 1.669	300		0.0625						3/8 x 2
	50 x 32	60.3 x 42.4	20		1.6						M10 x 50
7010111	2 x 1-1/2	2.375 x 1.9	300	1327	0.0625	1° - 31'	27	3.23	5.12	1.81	3/8 x 2-1/8
	50 x 40	60.3 x 48.3	20	5.91	1.6	1° - 31'	0.32	82	130	46	M10 x 50
7010112	2-1/2 x 2	2.875 x 2.375	300	1945	0.0625	1° - 15'	22	3.82	5.94	1.81	3/8 x 2-1/8
	65 x 50	73 x 60.3	20	8.66	1.6	1° - 15'	0.26	97	151	46	M10 x 50
7010113	3 x 2	3.5 x 2.375	300	2885	0.0625	1° - 02'	18	4.41	6.56	1.81	1/2 x 2-5/8
	80 x 50	88.9 x 60.3	20	12.84	1.6	1° - 02'	0.22	112	166.6	46	M12 x 65
7010114	3 x 2-1/2	3.5 x 2.875	300	2885	0.0625	1° - 02'	18	4.41	6.56	1.81	1/2 x 2-5/8
	80 x 65	88.9 x 73.0	20	12.84	1.6	1° - 02'	0.22	112	166.6	46	M12 x 65
7010115	4 x 2	4.5 x 2.375	300	4769	0.125	1° - 36'	28	5.55	7.87	1.97	1/2 x 2-5/8
	100 x 50	114.3 x 2.375	20	21.22	3.2	1° - 36'	0.34	141	200	50	M12 x 65
7010116	4 x 2-1/2	4.5 x 2.875	300	4769	0.125	1° - 36'	28	5.55	7.87	1.97	1/2 x 2-5/8
	100 x 65	114.3 x 73.0	20	21.22	3.2	1° - 36'	0.34	141	200	50	M12 x 65
7010117	4 x 3	4.5 x 3.5	300	4769	0.125	1° - 36'	28	5.58	7.87	1.97	1/2 x 2-5/8
	100 x 80	114.3 x 88.9	20	21.22	3.2	1° - 36'	0.34	141.8	200	50	M12 x 65
7010118	5 x 4	5.56 x 4.5	300	7124	0.125	1° - 18'	23	6.65	9.25	2.05	5/8 x 3-1/8
	125 x 100	139.7 x 114.3	20	31.70	3.2	1° - 18'	0.27	169	235	52	M16 x 80
7010119	6 x 4	6.625 x 4.5	300	9950	0.125	1° - 07'	20	7.76	10.83	2.05	5/8 x 3-1/8
	150 x 100	165.1 x 114.3	20	44.27	3.2	1° - 07'	0.24	197	275	52	M16 x 80
7010120	8 x 6	8.625 x 6.625	300	17524	0.125	1° - 50'	15	10.08	13.23	2.28	3/4 x 4-1/3
	200 x 150	219.1 x 168.3	20	77.97	3.2	1° - 50'	0.18	256	336	58	M20 x 110

- Deflection or angular movement is the maximum value that a coupling allows under no internal pressure.
- Working Pressure and End Load are total, from all internal and external loads, based on standard weight (ANSI) steel pipe, standard roll or cut grooved in accordance with ARGCO specifications.
- The allowable pipe separation dimension shown is for system layout purposes only. ARGCO couplings are considered rigid connections and will not accommodate expansion or contraction of the piping system.

System No.		Location		Spec Section		Paragraph	
Submitted By		Date		Approved		Date	

GROOVED REDUCING COUPLINGS

Model 105



INSTALLATION INSTRUCTIONS:

Depressurize and drain the piping system before attempting to install, remove, or adjust any piping products. Wear safety glasses, hardhat, and foot protection.

1. CHECK PIPE ENDS:

The outside surface of the pipe from the pipe end to the groove must be smooth and free from indentations, projections (including weld seams), and roll marks to ensure a leaktight seal for the gasket. All oil, grease, loose paint, and dirt must be removed.

2. CHECK GASKET AND LUBRICATE :

Check the gasket to make sure it is suitable for the intended service. Apply a thin coat of Tuf-Lube Gasket Grease Lubricant to the gasket lips and exterior.

3. POSITION GASKET:

Position the gasket over the pipe end. Make sure the gasket does not overhang the pipe end.

4. JOIN PIPE ENDS:

Align and bring the two pipe ends together. Slide the gasket into position, and make sure it is centered between the grooves in each pipe. Make sure no portion of the gasket extends into the groove in either pipe.

5. ASSEMBLE HOUSINGS:

Insert one bolt into the housings, and thread the nut loosely onto the bolt (nut should be flush with end of bolt) .

6. INSTALL HOUSINGS:

Install the housings over the gasket. Make sure the housings' keys engage the grooves properly on both pipes.

Torque Value

When a torque value is specified for coupling installation, this torque **MUST** be applied to the nuts in order to achieve proper installation. However, torque beyond specified values will not improve sealing. Exceeding the specified torque by more than 25% may cause damage to the product, resulting in pipe-joint failure.

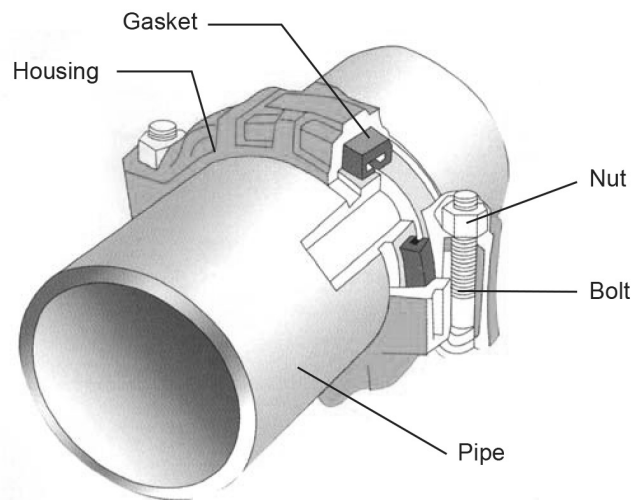

SPECIFIED TORQUE (LB/FT.)

SIZE	MIN	MAX
1"	30	45
1-1/4"	30	45
1-1/2"	30	45
2"	80	100
2-1/2"	80	100
3"	80	100
3-1/2"	100	130
4"	100	130

Using Impact Wrenches

When using an impact wrench, the speed of assembly may require extra care to ensure nuts are tightened evenly by alternating sides until proper assembly is complete. Impact wrenches do not provide the installer with direct "wrench feel" or torque to judge nut tightness. Since some impact wrenches are capable of high output, it is important to develop a familiarity with the impact wrench to avoid damaging or fracturing bolts or coupling bolt pads during installation.

DO NOT continue to use an impact wrench after the visual installation guidelines for the coupling are achieved.

Perform trial assemblies with the impact wrench and socket or torque wrenches to help determine the capability of the impact wrench. Using the same method, periodically check additional nuts throughout the system installation.

In addition, verify that proper impact grade sockets are being used for coupling installation.