

FIRE SPRINKLER GAUGE KIT TRIM FOR RISER CHECK VALVE

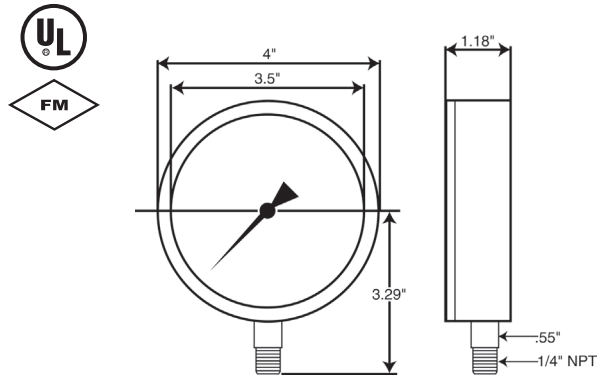

ARGCO's Sprinkler Gauge Kits provide everything needed to install a fire sprinkler gauge to a riser or other device.

Each kit contains a pressure gauge that is UL Listed and FM approved for Fire Sprinkler Service,

- 1/4" brass 3-way valve
- 1/4" x 1/2" galvanized reducer
- 1/4" IPS x 4" galvanized pipe nipple
- 1/4" IPS galvanized plug

Available with Water, Air-Water, Air or Air with Retard fire sprinkler gauge.

Gauge Specs:

Size: 4" (100 mm)

Accuracy ± 3/2/3% of span - 1 1/2" (ASME B40.1 Grade B)

Working Range

Steady: 3/4 of full scale value
 Fluctuating: 2/3 of full scale value
 Short time: full scale value

Operating Temperature

Ambient: -40°F to 140°F (-40°C to 60°C)
 Media: max. 140°F (+60°C)

Temperature Error

Additional error when temperature changes from reference temperature of 68°F (20°C) +0.4% for every 18° F (10°C) rising or falling. Percentage of span.

Standard Features

Connection Material: copper alloy
 Lower mount (LM) - not available for 1 1/2" size
 1/4" NPT limited to wrench flat area

Bourdon Tube: Material: copper alloy C-type

Movement: Copper alloy, silicone dampened

Dia: White plastic with stop pin - black & red lettering

Pointer: Black aluminum

Case: Black polycarbonate

- 6510160KIT: AIR/WATER GAUGE KIT
- 6510161KIT: WATER GAUGE KIT
- 6510-162KIT: AIR GAUGE WITH RETARD KIT
- 651063KIT: AIR GAUGE KIT

System No.		Location		Spec Section		Paragraph	
Submitted By		Date		Approved		Date	