

MECHANICAL TEE (THREAD)

Model 403



The Model 403 Mechanical Tee provides a fast and easy mid-pipe threaded branch outlet. It eliminates the need for welding or multiple fittings. The mechanical tee utilizes ductile iron housings, a grade E molded gasket and heat-treated carbon steel track bolts and nuts. Pressure rated to 300 psi (20 bar).

Pipe Material

- Carbon steel, Schedule 10, Schedule 40.
- For use with alternative materials and wall thicknesses please contact ARGCO.

Maximum Working Pressure

- Up to 300 psi/20 bar

Function

- Joins carbon steel pipe.
- Provides a rigid pipe joint designed to restrict axial or angular movement.

CERTIFICATIONS/LISTINGS

Underwriters Laboratories, Underwriters Laboratories Canada, Factory Mutual.

SPECIFICATIONS - MATERIAL

Housing Sections: Ductile Iron conforming to ASTM A 536, Grade 65-45-12.

Housing Coating:

Standard: Orange Enamel
Available: Hot Dipped Galvanized

Gasket:

Standard: Grade E EPDM (Type A)
ARGCO's products are listed by Underwriters Laboratories UL Canada and Approved by Factory Mutual for we and dry (oil free air) sprinkler services within the rated working pressure.

Bolts and Nuts

Standard: Carbon Steel oval neck track bolts meeting ASTM A449 and ISO 898-1. Carbon steel hex nuts meet ASTM A563 Grade B.
Nuts and Bolts are zinc electroplated per ASTM B633 NZ/FE5, finish Type III.
Available: Stainless Steel. Meets ASTM F593, Group 2 (316 stainless steel), condition CW.
Hex nuts meets ASTM F594, Group 2 (316 stainless steel), condition CW, with galling-resistant coating.

System No.		Location		Spec Section		Paragraph	
Submitted By		Date		Approved		Date	

MECHANICAL TEE (THREAD)

Model 403

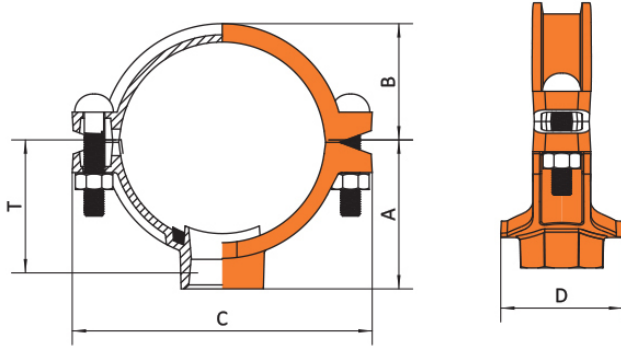

Item #	Nominal Size in/mm	Pipe O.D.	Hole Dia. \mp +3.2,-0 /+0.13,-0	Dimensions - in/mm					Bolt Size in/mm
				T \ddagger	A	B	C	D	
7010302	2 x 3/4	2.375 x 1.05	1.25	1.97	2.20	1.65	4.72	2.99	3/8 x 2-3/8
	50 x 20	60.3 x 26.7	32	50	56	42	120	76	M 10 x 60
7010303	2-1/2 x 3/4	2.875 x 1.05	1.25	2.02	2.42	1.85	5.63	2.99	1/2 x 2-5/8
	65 x 20	73 x 26.7	32	56	61.5	47	143	76	M 12 x 65
7010304	2 x 1	2.375 x 1.327	1.50	1.85	2.20	1.65	4.72	2.99	3/8 x 2-3/8
	50 x 25	60.3 x 33.7	38	47	56	42	120	76	M 10 x 60
7010305	2 x 1-1/4	2.375 x 1.669	1.75	2.05	2.68	1.65	4.72	3.31	3/8 x 2-3/8
	50 x 32	60.3 x 42.4	44.5	52	68	42	120	84	M 10 x 60
7010306	2 x 1-1/2	2.375 x 1.9	2.00	2.05	2.80	1.65	4.72	3.37	3/8 x 2-3/8
	50 x 40	60.3 x 48.3	50	52	71	42	120	84	M 10 x 60
7010307	2-1/2 x 1	2.875 x 1.327	1.50	2.09	4.42	1.85	5.63	2.99	1/2 x 2-5/8
	65 x 25	73.0 x 33.7	38	53	61.5	47	143	76	M 12 x 65
7010308	2-1/2 x 1-1/4	2.875 x 1.669	1.75	2.28	2.89	1.85	5.63	3.31	1/2 x 2-5/8
	65 x 32	73.0 x 42.4	44.5	58	73.5	47	143	84	M 12 x 65
7010309	2-1/2 x 1-1/2	2.875 x 1.9	2.00	2.28	2.89	1.85	5.63	3.54	1/2 x 2-5/8
	65 x 40	73.0 x 48.3	50	58	73.5	47	143	90	M 12 x 65
7010311	3 x 1	3.5 x 1.327	1.50	2.40	2.74	2.17	6.22	2.99	1/2 x 2-5/8
	80 x 25	88.9 x 33.7	38	61	69.5	55	158	76	M 12 x 65
7010312	3 x 1-1/4	3.5 x 1.669	1.75	2.56	3.19	2.17	6.22	3.31	1/2 x 2-5/8
	80 x 32	88.9 x 42.4	44.5	65	81	55	158	84	M 12 x 65
7010313	3 x 1-1/2	3.5 x 1.9	2.00	2.80	3.19	2.17	6.22	3.54	1/2 x 2-5/8
	80 x 40	88.9 x 48.3	50	71	81	55	158	90	M 12 x 65
7010314	3 x 2	3.5 x 2.375	2.50	2.76	3.19	2.17	6.22	3.98	1/2 x 2-5/8
	80 x 50	88.9 x 60.3	63.5	70	81	55	158	101	M 12 x 65
7010315	4 x 1	4.250 x 1.327	1.50	2.87	2.99	2.44	6.57	2.99	1/2 x 2-5/8
	100 x 25	108.1 x 33.7	38	73	76	62	167	76	M 12 x 65
7010316	4 x 1-1/4	4.25 x 1.669	1.75	3.07	2.99	2.44	6.57	3.27	1/2 x 2-5/8
	100 x 32	108.0 x 42.4	44.5	78	76	62	167	83	M 12 x 65
7010317	4 x 1-1/2	4.25 x 1.9	2.00	3.27	2.99	2.44	6.57	3.54	1/2 x 2-5/8
	100 x 40	108.0 x 48.3	50	83	76	62	167	90	M 12 x 65
7010318	4 x 2	4.25 x 2.375	2.50	3.27	3.07	2.44	6.57	3.94	1/2 x 2-5/8
	100 x 50	108.0 x 60.3	63.5	83	78	62	167	100	M 12 x 65
7010319	4 x 2-1/2	4.25 x 3	3.00	2.87	4.13	2.44	6.57	4.61	1/2 x 2-5/8
	100 x 65	108.0 x 76.1	76	73	105	62	167	117	M 12 x 65

Continued on next page

MECHANICAL TEE (THREAD)

Model 403

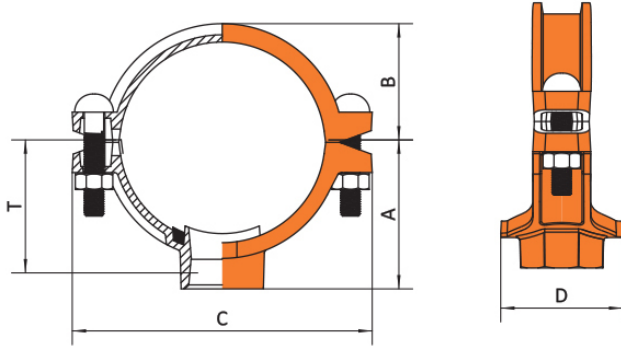

Item #	Nominal Size in/mm	Pipe O.D.	Hole Dia. \bar{T} +3.2,-0 /+0.13,-0	Dimensions - in/mm					Bolt Size in/mm
				T†	A	B	C	D	
7010321	4 x 3	4.5 x 3.5	3.50	3.31	3.94	2.56	7.13	5.35	1/2 x 2-3/4
	100 x 80	114.3 x 88.9	89	84	100	65	181	136	M 12 x 70
7010322	5 x 1	5.250 x 1.327	1.50	3.35	3.50	2.91	8.07	2.99	1/2 x 3
	125 x 25	133.0 x 33.7	38	85	89	74	205	76	M 12 x 75
7010323	5 x 1-1/4	5.25 x 1.669	1.75	3.54	3.50	2.91	8.07	3.27	1/2 x 3
	125 x 32	133.0 x 42.4	44.5	90	89	74	205	83	M 12 x 75
7010324	5 x 1-1/2	5.25 x 1.9	2.00	3.74	3.50	2.91	8.07	3.54	1/2 x 3
	125 x 40	133.0 x 48.3	50	95	89	74	205	90	M 12 x 75
7010325	5 x 2	5.25 x 2.375	2.50	3.74	3.50	2.91	8.07	3.94	1/2 x 3
	125 x 50	133.0 x 60.3	63.5	95	89	74	205	100	M 12 x 75
7010326	5x 2-1/2	5.25 x 3	3.00	3.82	3.62	2.91	8.07	4.61	1/2 x 3
	125 x 65	133.0 x 76.1	76	97	92	74	205	117	M 12 x 75
7010327	5 x 3	5.25 x 3.5	3.50	4.17	3.70	2.91	8.07	5.08	1/2 x 3
	125 x 80	133.0 x 88.9	92	106	94	74	205	129	M 12 x 75
7010328	6 x 1	6.250 x 1.327	1.50	4.45	4.00	3.58	9.17	2.99	9/16 x 3
	150 x 25	159 x 33.7	38	113	101.5	91	233	76	M 14 x 75
7010329	6 x 1-1/4	6.250 x 1.669	1.75	4.45	4.00	3.58	9.17	3.27	1/2 x 3
	150 x 32	159.0 x 42.4	46	113	101.5	91	233	83	M 12 x 75
7010330	6 x 1-1/2	6.250 x 1.9	2.00	4.41	4.00	3.58	9.17	3.54	1/2 x 3
	150 x 40	159.0 x 48.3	53	112	101.5	91	233	90	M 12 x 75
7010331	6 x 2	6.250 x 2.375	2.50	4.37	4.00	3.58	9.17	3.94	1/2 x 3
	150 x 50	159.0 x 60.3	64	111	101.5	91	233	100	M 12 x 75
7010332	6 x 2-1/2	6.250 x 3	3.00	4.37	4.15	3.58	9.17	4.61	5/8 x 3-1/3
	150 x 65	159.0 x 76.1	76	111	105.5	91	233	117	M 16 x 85
7010333	6 x 3	6.250 x 3.5	3.50	4.33	4.15	3.58	9.17	5.08	5/8 x 3-1/3
	150 x 80	159.0 x 88.9	89	110	105.5	91	233	129	M 16 x 85
7010334	8 x 1	8.625 x 1.327	1.50	5.98	5.35	1.92	12.68	2.99	5/8 x 3-1/2
	200 x 25	219.1 x 33.7	38	152	136	125	322	76	M 20 x 90
7010335	8 x 1-1/4	8.625 x 1.669	1.75	5.98	5.79	1.92	12.68	3.31	5/8 x 3-1/2
	200 x 32	219.9 x 42.4	44.5	152	147	125	322	84	M 20 x 90
7010336	8 x 1-1/2	8.625 x 1.9	2.00	5.98	5.79	1.92	12.68	3.54	5/8 x 3-1/2
	200 x 40	219.1 x 48.3	50	152	147	125	322	90	M 20 x 90
7010337	8 x 2	8.625 x 2.375	2.50	5.43	5.79	1.92	12.68	3.98	5/8 x 3-1/2
	200 x 50	219.1 x 60.3	64	138	147	125	322	101	M 20 x 90
7010338	8 x 2-1/2	8.625 x 3	3.00	5.08	6.14	1.92	12.68	4.61	5/8 x 3-1/2
	200 x 65	219.1 x 76.1	76	129	156	125	322	117	M 20 x 90
7010339	8 x 3	8.625 x 3.5	3.50	5.31	6.24	1.92	12.68	136	5/8 x 3-1/2
	200 x 80	219.1 x 88.9		135	158.5	125	322	5.35	M 20 x 90

Nuts must be torqued to 50 ft/lbss [68 N/m]. Do not exceed 70 ft/lbs [90N/m] of torque. Increased bolt torque will not improve sealing and may cause product failure.