

data sheet

ARGCO

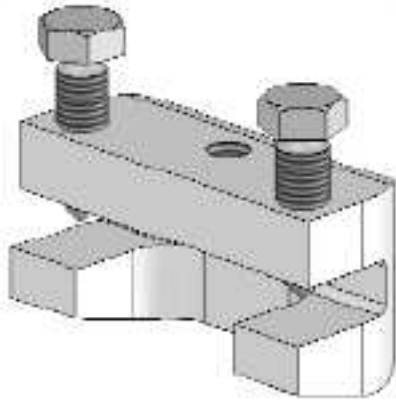

Model 035 SWAY BRACE BAR JOIST ADAPTER



FUNCTION:

Sway brace adapter used to attach a PHD Manufacturing sway brace assembly to a steel bar joist structural member of 3/8" maximum thickness.

To provide a point of connection when drilling or welding is not allowed or impractical.

Sway brace assemblies are intended to be installed in accordance with NFPA 13 and the manufacturer's installation instructions.

SIZE: 1/2" mounting bolt hole and UL Listed for 8" Pipe MAX

FINISH: Electro-galvanized

MATERIAL: Ductile Iron

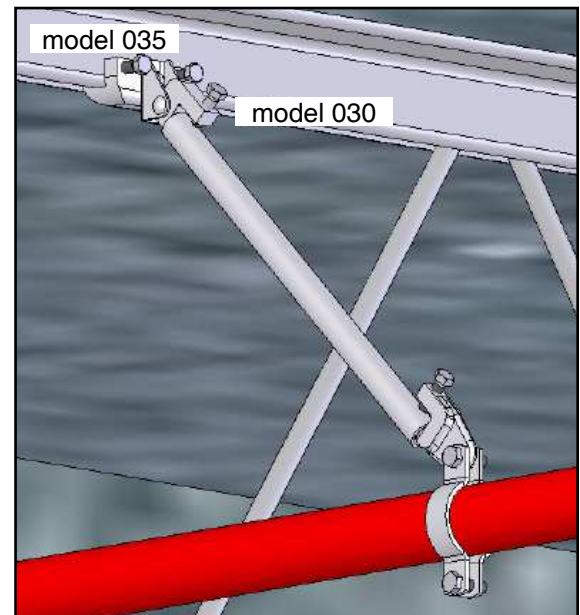

INSTALLATION:

Steel bar joist manufacturer's warranty requires attachment within 6" of chord panel point.

Place on structural member with the flange contacting the back of the jaw.

Tighten set screws finger tight, then evenly tighten until hex head breaks off.

APPROVALS:

Underwriters Laboratories listed for US and Canada

Listed for use with NFPA and PHD sway brace components only

Max. Pipe Size	Max. Rec. Load
8"	2015 lbs.

CROSS REFERENCE:

Erico: CSBBAR

Afcon: 087

Tolco: 825, 825A

The information contained herein is produced in good faith and is believed to be reliable but is for guidance only. ARGCO and its agents cannot assume liability or responsibility for results obtained in the use of its product by persons whose methods are outside or beyond our control. It is the user's responsibility to determine the suitability of any of the products, methods of use, or preparation prior to use, mentioned in our literature. It is the user's responsibility to observe and adapt such precautions as may be advisable for the protection of personnel and property in the handling and use of any of our products.

**FOR MORE INFORMATION CALL ARGCO AT 1-800-854-1015
OR LOG ONTO WWW.ARGCO.COM**