

# data sheet

# ARGCO



## Tri-Stand Chain Vise 6"



- Large working surface, 6" pipe capacity
- Integral legs and tray fold in for easy carrying and set up.
- Large vise base overhangs front legs for clear tool swing.
- Complete with slots for hanging tools, pipe rest, three pipe benders, and ceiling brace screw.

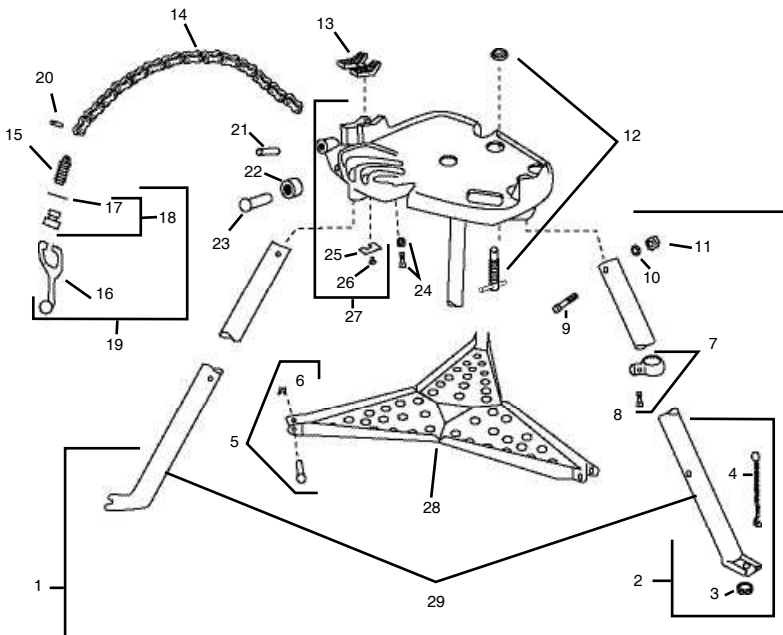

REF	PART #	DESCRIPTION
-	33-05-100	TS Tri Stand Chain Vise 6" Complete
1	33-05-101	TS Leg & tray assy.
2	33-05-102	TS Rear leg assy.
3	33-03-116	Stand Grommet (5 pack)
4	33-03-112	Stand Leg chain
5	33-03-109	Stand Tray pin with washer (5 pack)
6	33-03-110	Stand washer (5 pack)
7	33-03-104	Stand tray support with screw
8	33-03-111	Stand Set screw 3/8" - 16 x 1"
9	33-03-106	Stand Hex bolt 3/8"-16 x 2-3/4" (5 pack)
10	33-03-108	Stand Lock washer 3/8" (5 pack)
11	33-03-107	Stand Nut 3/8" - 16 (5)
12	33-05-112	TS Jack screw assy.
13	33-05-113	TS Jaw
14	33-05-114	TS Chain assy. (incl. #20)
15	33-05-115	TS Chain screw
16	33-05-116	TS Handle
17	33-05-117	TS Friction ring
18	33-05-118	TS Swivel nut
19	33-05-119	TS Handle assy.
20	33-05-120	TS Chain screw pin
21	33-05-121	TS Nut locking pin
22	33-05-122	TS Roll
23	33-05-123	TS Roll pin
24	33-05-124	TS Jaw screw w/washer (2 pack)
25	33-05-125	TS Wear plate
26	33-05-126	TS Screw w/washer (2)
27	33-05-127	TS Base w/wearplate & screws
28	33-05-128	TS Tool tray
29	33-05-129	TS Front leg assy w/grommet (2)
	33-05-130	TS Replacement legs (set of 3)

### TRI-STAND CHAIN VISE

#### *Assembly instructions:*

- (1) First, slide the Rear Leg Assembly (#7) through the Tray Support Ring (#3). Insure that the Rear Leg Assembly is correctly facing away from the Tool Tray (#1), the foot is facing outwards and that the Tool Tray (#1) could fold upwards. You can tighten set screw (#4).
- (2) Next, place one Front Leg Assembly (#6) into the Tool Tray (#1). Check that the foot is down and facing outwards. Push Tray Pin (#2) through the holes provided in the Front Leg Assembly (#6) and the Tool Tray (#1). Lock in place with the "X" shaped washer by tightening with pliers.
- (3) Repeat same process for the second Front Leg Assembly (#6).
- (4) Put the Base Assembly (#22) upside-down on the floor. Insert the three legs into the slots remembering that the Rear Leg Assembly (#7) is opposite the chain and vise jaws. Push the Leg Bolts (#5) through the holes provided and tighten the nuts and lockwashers.
- (5) Pick up Tristand and place right side up. Insure that the Tool Tray (#1) is firmly seated. You may adjust the correct location of set screw (#4) for the Rear Leg Assembly (#7).

